

PowerBoss®
The Power of Clean



User Manual PHX28/30/33



PowerBoss, Inc.
A member Of The Hako Group

988745UMPB REV A 09/25

Introduction

Preface

Dear customer,

It is our desire that the good characteristics of the Phoenix 26 should justify the confidence you demonstrated by making this purchase. Prior to the first operation, carefully read the chapter "Safety Information" in order to ensure your safety working with the machine. Your own safety, as well as the safety of others, depends greatly on how the vehicle is moved and operated. Therefore, carefully read and understand this manual before operation.

This manual provides valuable information about operation, service and maintenance. The warning symbols used in this manual identifies items that are relevant to safety. Please observe the safety provisions (see chapter "Safety Information").

Your authorized PowerBoss dealer will be pleased to answer further questions regarding the unit or the operation and maintenance manual. Please be advised explicitly that we cannot accept any legal issues out of the contents of this manual. If repair work must be performed make sure that only genuine spare parts are used. Genuine spare parts help guarantee a dependable machine. We reserve the right to make changes without notice.

Valid as of: November 2011

PowerBoss Inc.
14N845 US Route 20
Pingree Grove, Illinois 60140

Proper use

The E26 machine is a vacuum scrubbing machine used for the wet cleaning of hard-surfaced floors. Using the machine beyond this scope of it's application will be deemed improper and negligent use. The manufacturer cannot be held liable for consequential damages, the user alone bears the risk. The term of proper use also includes operation, maintenance and repair work to be performed in compliance with the manufacturer's specifications. The Phoenix 26 may be used by Qualified persons familiar with the machine and aware of possible hazards involved.

The applicable Accident Prevention Regulations and further regulations concerning safety and work must be complied with.

If modifications to the machine are made in absence of the manufacturer's prior consent, PowerBoss cannot be held liable for damage resulting from such unauthorized modification.

Notes on warranty

The terms of the sales contract apply. Damages are not subject to warranty if they are due to non-compliance with the maintenance and service provisions.

The maintenance work has to be performed by an authorized PowerBoss service center and confirmed in the "Maintenance Certificate" which is the warranty document.

The following is excluded from warranty: fuses, natural wear items such as squeegee blades, skirts and brushes. Damages caused by overload, negligence and unauthorized modification of the machine are not covered by warranty. Moreover, any claim for warranty cannot be accepted if damages of the machine are caused by improper fitting of parts or accessories without PowerBoss's prior consent, or by non-compliance with the maintenance instructions and schedule.

Acceptance of the machine

Upon arrival, check machine for possible damages in transit. Follow unpacking instructions on shipping pallet. Each unit has been tested and thoroughly inspected before shipment. Any damage is the responsibility of the delivery carrier who should be notified immediately. For refund of such damage, have the freight forwarder confirm damage and mail notification along with waybill to:

PowerBoss Inc.
14N845 US Route 20
Pingree Grove, Illinois 60140

Table of Contents





1 Safety information	6	3.1.2 Solution Tank	12
1.1 Safety and Warning Symbols	6	3.1.3 Squeegee	13
1.2 General Provisions	6	3.1.4 Recovery Tank	13
1.3 Provisions for Operation.....	7	3.1.5 Drive System.....	13
1.4 Maintenance instructions.....	7	3.1.6 Batteries and Charger.....	13
1.5 Specific Hazards	8	3.1.7 Options.....	13
1.6 Information for Protection of Environment	8	3.2 Control Panel & Operation Indicators	14
1.7 Labels On The Machine.....	9	3.2.1 Operating Panel.....	14
2 First Operation	10	3.2.2 At The Machine	16
2.1 Instruction	10	4 Technical Data	18
2.2 Initial Charging Procedure	10	5 Maintenance and Care	20
2.3 Before Operation Of Machine	10	5.1 General.....	20
2.4 Start Machine	10	5.2 Maintenance Document.....	21
2.5 Operation	10	5.3 Maintenance Schedule	22
2.6 Stopping The Machine.....	11	5.4 Battery Systems.....	25
2.7 After Work.....	11	5.4.1 Charging The Batteries.....	26
2.8 Transport Mode	11	5.4.2 Low Discharge Signal Sender (LDS).....	26
2.9 Tie Down Points	11	5.4.3 Removing Batteries.....	26
3 Operation	12	5.4.4 Installing Batteries	26
3.1 Method Of Operation	12	5.4.5 Disposal of Batteries.....	26
3.1.1 Scrub Head Assembly	12	5.5 Solution Tank	27
		5.5.1 Filling the Solution Tank	28
		5.5.2 Empty the Solution Tank	28

5.5.3	Cleaning Clear Water Filter	28
5.6.1	Empty Recovery Tank	30
5.6.2	Cleaning the Recovery Tank	30
5.6.3	Clean Suction Filter.....	30
5.7	Scrub Head	31
5.7.1	Cleaning Brushes.....	31
5.7.2	Changing Brushes	31
5.7.3	Changing Deflector Roller.....	31
5.7.4	Changing Scrub Head Skirt	31
5.8	Cylindrical Brush Deck.....	32
5.8.1	Clean Dirt Hopper.....	32
5.8.2	Remove Brushes	32
5.8.3	Clean Brushes	32
5.8.4	Fit Brushes	32
5.8.5	Change Deflector Roller	32
5.9	Squeegee	33
5.9.1	Cleaning the Squeegee.....	33
5.9.2	Changing the Squeegee Blades.....	33
5.9.3	Adjusting the Blades Angle Adjustment	34

1 Safety information

1.1 Safety and Warning Symbols

All paragraphs in this manual referring to your personal safety, the safety of your machine and the environment protection are recognized by one of the following warning symbols:

Symbol	Hazardous for ...	Description
Warning 	Persons and Goods	Indicates a hazardous situation which could result in death or serious injury.
Note 		Indicates important or additional information.
Ecological Hazard 	The Environment	Indicates the use of substances representing an inherent danger to the health of the environment.
NOTICE 	All	Indicates a potentially hazardous situation which may result in equipment or property damage.

1.2 General Provisions

- Apart from the provisions contained in this instruction manual, the general safety provisions and the accident prevention regulations as imposed by law must be complied with.
- Before operating your machine, carefully read the instruction manual as well as other separate instructions for accessories or attached implements. Comply with all points mentioned there during work.
- Only persons trained by qualified PowerBoss personnel are authorized to operate, service and repair the machine.
- You are advised to thoroughly study the safety instructions, this will help in avoiding errors during operation of the machine and thus guarantees correct usage of the machine.
- The operating instructions must be on hand at the place of machine use, and therefore have to be kept readily available at the machine.
- When selling or lending the machine for rent, hand out these documents to

the new owner/operator and have the transfer certified!

- The warning and instruction plates attached to the machine contain valuable advice about safe operation. Immediately replace incomplete or illegible labels.
- For safety standards spare parts must be equal to genuine parts!

1.3 Provisions for Operation

- Before the first operation of the machine, fully charge the battery with an initial charging procedure and comply with the operating instructions of the charger as well as with those of the battery manufacturer. PowerBoss cannot be held liable for damages resulting from the fact that the initial charging has not or insufficiently done.
- Before operation, check the machine for operational safety! **Immediately remedy malfunctions!**
- It is necessary for the operator to get acquainted with all attachments

and controls as well as with their function before operation begins.

- When operating the machine use of firm and skid proof shoes is recommended.
- The machine may be used only on such surfaces clearly specified by the owner or his authorized representative.
- When operating the machine take notice of persons within the operation area especially children.
- Start moving immediately after brush head has lowered otherwise the brush might leave traces on the surface. Lift the brush head before going over obstacles (doorsteps).
- Empty dirty water tank before folding recovery tank over.
- Use only cleaning agents suitable for automatic machines (low-foaming) and comply with the instructions for use, disposal and with the warning information specified by the cleaning agent's manufacturer.
- The machine is not designed for collecting hazardous, inflammable or explosive dust or substances.

- Usage of the machine in explosive areas is prohibited.
- Pull the ignition key to avoid unauthorized use of the machine.
- Before transporting the machine, lift the squeegee and the scrub head assemblies. Adapt operation of machine to the local conditions.
- The machine may be used only for operation on plane areas with a maximum inclination of 2 %.

1.4 Maintenance instructions

- The daily and weekly maintenance and repair task must be performed by a qualified operator. For any maintenance and repair work beyond this please contact your local PowerBoss service center.
- Observe the maintenance activities and intervals set out in the instruction manual.
- Maintenance and repair work should be carried out with use of the appropriate tools.
- Have the machine checked for safety conditions in the sense of the

Accident Prevention Regulation by an expert at regular intervals recommendation: (at least once yearly) as well as after modifications or repairs.

- Spare parts must be equal to the technical requirements as specified by the manufacturer. Using genuine spare parts guarantee compliance with these requirements.
- Stop engine before proceeding to inspection and maintenance work.
- To prevent the machine from being used by unauthorized persons, the ignition key should be removed.
- When performing work on the electrical system, be sure to disconnect the battery plug.
- Make sure to protect the dirty water tank against accidental closing or tilting down before working in the area of a lifted tank lid.
- Do not clean the electrical parts by means of high-pressure cleaning equipment.
- The use of aggressive detergents

is not recommended.

- Let the machine dry after cleaning i.e. for the weekend.
- The machine may become operational after all protective devices have been fitted and positioned.

1.5 Specific Hazards

Electric system

- Only use genuine fuses with the correct rating.
- In case of malfunction of the electrical system, immediately shutdown machine and make repairs.
- Only qualified personnel is authorized to make repairs to this electrical equipment according to electrical & technical guidelines
- Inspect/check the electrical equipment of the machine at regular intervals. Immediately repair defects such as i.e. loose connections or scorched cables.

Battery

- Follow the operating instructions of the battery manufacturer.

- Handling and changing of the batteries may take place only by maintenance staff or qualified technician.
- Never place metal objects or tools on batteries this is a short-circuit hazard!
- Do not change the center of gravity, only use recommended batteries at the prescribed position.
- Provide sufficient ventilation to areas where batteries are being charged.
- Explosion hazard!

1.6 Information for Protection of Environment

- Observe the legal directives and local regulations for disposal of detergents, see Water Management Act.
- Used batteries labeled as recyclable contain reusable economic goods. These batteries must not be added to the normal waste.

1.7 Labels On The Machine

The following safety and information labels are legibly attached to the machine. Replace missing or illegible labels immediately.

PowerBoss Decal (Fig. 1/1)



Machine identification number (Fig. 1/2)

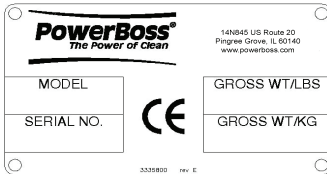

Dirty water drain hose (Fig. 1/3)



A = Read and observe the instruction manual (Fig. 1/2)
B = Maximum inclination of 2 % (Fig. 1/2)
C = Do not clean the machine by means of high-pressure cleaning equipment (Fig. 1/2)

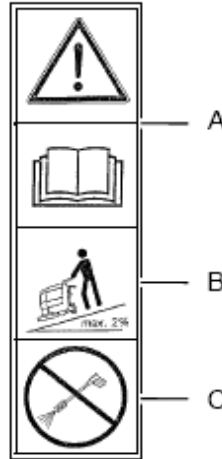

Inflation Pressure (Fig. 1/4) = 65 psi



Fig.1

2 First Operation

2.1 Instruction

Instruction is required before the first operation. First instruction into handling of the machine must be held by a qualified person sent by your local PowerBoss dealer. Your PowerBoss dealer will be informed upon delivery of the unit and will contact you to make a date for instruction.

2.2 Initial Charging Procedure



Before first operation of the machine, fully Charge the battery with an initial charging procedure and comply with the operating instructions of the charger as well as with those of the battery manufacturer. PowerBoss cannot be held liable for damages resulting from the fact that the initial charging has not or insufficiently been done.

2.3 Before Operation Of Machine

Perform the following inspections

before operation.

1. Check parking site for signs of leakage. Hoses, lines and tanks must be free from any leakage or damage.
2. Install brushes and squeegee, see maintenance chapter.
3. Install batteries and connect battery cable, see maintenance chapter.
4. Check battery charge and proceed to charging of batteries if required. Generally proceed to initial charging before first operation of the machine.
5. Empty dirty water Recovery tank and clean it if required, see maintenance chapter.
6. Fill clean water tank and add a cleaning agent according to the manufacturer's recommendations.



Use only cleaning agents suitable for automatic machines (low-foaming type) and comply with the instructions for use. Follow directions for disposal and warning information as specified by the manufacturer.

2.4 Start Machine

Before starting the machine, set the forward/reverse level to neutral position. If the lever is not in the neutral position when machine is switched on, an error message will occur. Use the following procedure reset the machine into operating mode:

- Disconnect main plug of the charger from outlet and fasten to the holder.
- Switch on the machine by turning the ignition key from position (0) to position (1).

2.5 Operation

1. Turn on the machine via ignition switch.
2. Use hand lever (Fig. 5/3) to lower squeegee. Vacuum motor turns on automatically.
3. Switch on clean water supply by solution switch (Fig. 4/14).
4. Adjust clear water amount by means of metering switch (Fig. 4/13).
5. Use pedal (Fig. 5/9) to lower brush head.
6. Use forward/reverse lever (Fig. 5/1) to adjust speed and direction. Increase the scrub brush pressure if required with pedal (Fig. 5/10) .



Start moving machine immediately after lowering the scrub head, otherwise the brushes may leave traces on the floor. Lift squeegee before changing to reverse. Lift up brush head before passing over dormers and more.

2.6 Stopping The Machine

Releasing the forward/reverse lever it returns automatically into the neutral position stopping the machine. This also protects the machine against unintentional movements or against being inadvertently started.

2.7 After Work

1. Park machine on a suitable site for maintenance.
2. Stop machine, lift squeegee and scrub head and pull the ignition key.
3. Empty and clean dirty water recovery tank.



Observe the legal directives and local regulations for disposal of detergents, see Water Management Act.

4. Check clean water filter.
5. Check squeegee blades and suction hose.
6. Check operation function and settings.
7. Charge batteries.
8. Clean the machine.

Empty the clean water solution tank before shutting down the machine for a long period of time.



Do not clean the electrical parts by means of high-pressure cleaning equipment.

2.8 Transport Mode

When transporting unit to; switch unit on, lift squeegee and scrub head and actuate the forward/reverse lever according to the desired direction of travel and speed.

2.9 Tie Down Points

When transporting unit on a vehicle or trailer, the machine must be protected against rolling off. Chock the drive wheel. Tie the machine down firmly to the front with the eye bolts (Fig. 2/1) and to the rear by the chassis (Fig. 2/2) .

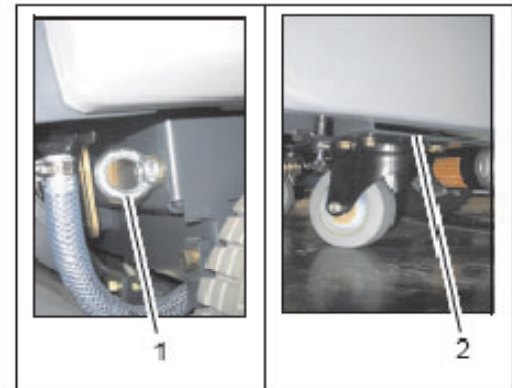

Fig.2

3 Operation

3.1 Method Of Operation

General

The E28/30/33 is a vacuum scrubbing machine for wet cleaning of hard surfaced floors.

3.1.1 Scrub Head Assembly

Lower the scrub head assembly (Fig. 3/1) via pedal before scrubbing. The brushes will rotate and the water supply turns on automatically.

When the forward/reverse lever is in the neutral position & machine is stopped, the scrub brushes & water supply is switch off automatically. Figure 3 represents the Disc scrub Head type machine.

A Cylindrical Scrub Head machine is also available.

3.1.2 Solution Tank

Fill the solution tank (Fig. 3/2) after folding up the opening. The solution tank holds approximately 19 gallons and the filling level can be seen looking through the transparent hose. Regulation of water amount is available via adjustment handle.



Fig.3

3.1.3 Squeegee

The movable squeegee (Fig. 3/3) consists of the squeegee lift handle, the vacuum motor and the squeegee blades. The dirty water is cleaned from the floor by means of the squeegee blades. The Squeegee is lowered via a hand lever. Simultaneously, the vacuum motor switches on. The vacuum motor works independent of travel direction or if the machine stops. A second actuation of the lever lifts the squeegee up again and the vacuum motor is automatically switched off with a delay of 15 seconds.

3.1.4 Recovery Tank

The dirty water is moved from the squeegee to the recovery tank (Fig. 3/4) by a vacuum motor and suction hose. For cleaning and collecting water in places where access is difficult, the machine is equipped with a handheld suction hose.

3.1.5 Drive System

The machine features a continuous drive (Fig. 3/5). The electronic drive controls travel speed and direction as well as dynamic braking.

3.1.6 Batteries and Charger

The machine is equipped with maintenance-free 180 Ah batteries (Fig. 3/6), an automatic charger (Fig. 3/7) and a low discharge signal sender (LDS) for protection against low discharge.

3.1.7 Options

- Extraction hose including suction pipe, joint nozzle and wet suction nozzle.
- Mop holder and tool-box for cleaning utensils.



Accessories such as brushes, rollers, pads, pad holder with centerlock and squeegee blades are available. Contact your PowerBoss Dealer for more information

3.2 Control Panel & Operation Indicators

3.2.1 Operating Panel

- 1 Display
- 2 Key Switch
- 3 Battery Charge Indicator
- 4 LDS Indicator
- 5 Symbol for Brush Drive
- 6 Symbol for Vacuum Motor
- 7 Hour Meter
- 8 Symbol for Service Indicator
- 9 Drive Direction Control (9a) with speed control knob (9b) and bail handle (9c)

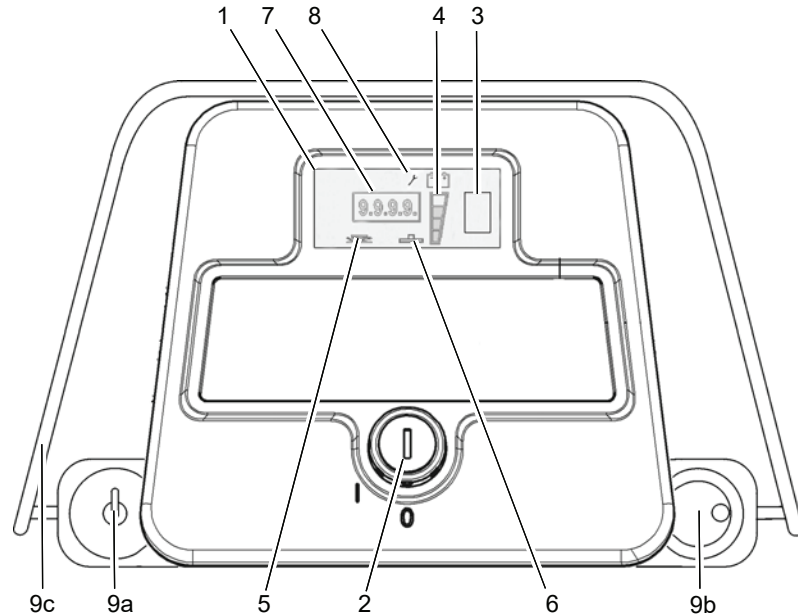

Display (Fig. 4/1)

This panel allows centralized monitoring of functions and status of all available operating modes.



Key Switch (Fig. 4/2)

The ignition key switch turns the electrical system on and off.



Pull the ignition key to avoid unauthorized use of the machine.

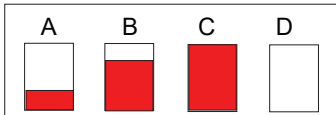

Battery Charge Indicator (Fig. 4/3)

The battery charge indicator appears on the panel during the charging procedure and shows the current charge condition of batteries during the charging procedure.

The following symbols appear:

Battery symbol A = charge of 20 %

Battery symbol B = charge of 80 %

Battery symbol C = charge of 100 %

Battery symbol D (flashes) = error

LDS Indicator (Fig. 4/4)

Upon switching on, the LDS indicator is illuminated on the panel to show the current battery charge condition during operation. For additional Information see chapter on maintenance.



Symbol For Scrub Brush (Fig. 4/5)

This symbol appears when the scrub brush is switched on.



Symbol For Vacuum Motor (Fig. 4/6)

This symbol appears when the vacuum motor is switched on.

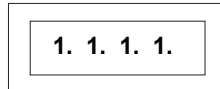

Hour Meter (Fig. 4/7)

When switched on, the hour meter briefly displays the software version and the last error code. Then the current operating hour level is shown.



Service Indicator (Fig. 4/8)

The service indicator is illuminated after an occurrence of a system error and if a cleaning procedure is interrupted. In addition to the service indicator, a 4-digit code is displayed on the hour meter.

Drive direction control with speed control knob and bail handle (Fig/ 4/9)

The drive direction control (9a) is used to control the driving direction (forward or reverse). The bail handle must be pulled in order to drive. The speed can be adjusted continuously by means of the speed control knob (9c). The machine stops when the bail handle is released (deadman function).



Secure the machine against rolling away before leaving it unattended.

3.2.2 At The Machine

- 1 Brush deck pedal
- 2 Opening of solution tank
- 3 Solution control
- 4 Squeegee lever
- 5 Solution tank filter
- 6 Recovery tank drain hose
- 7 Solution tank drain hose (Solution level indicator)
- 8 Brush ejector
- 9 Power Cord For Charger

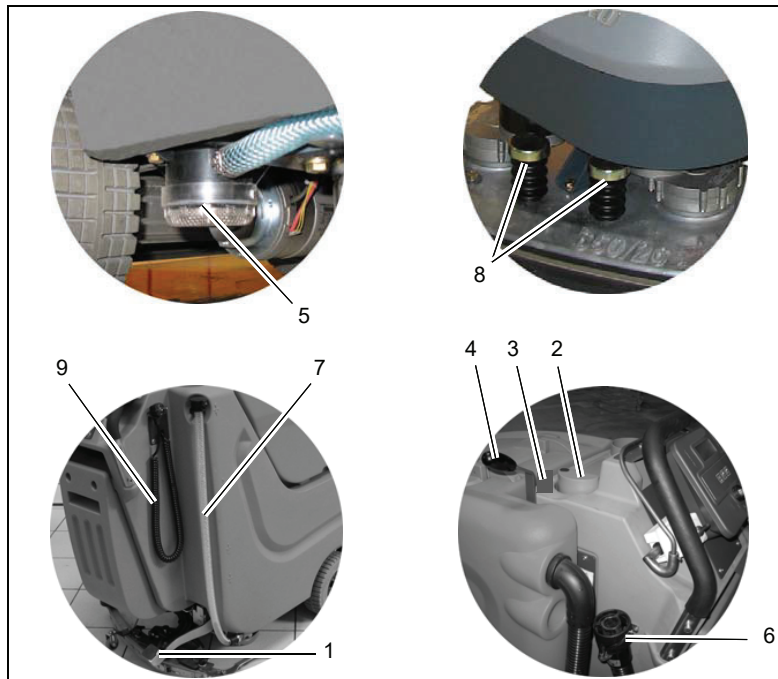

Fig.5

Brush deck pedal (Fig. 5/1)

Use this pedal to lift and lower the brush deck.

Opening of solution tank (Fig.5/2)

The solution tank is filled after folding up the opening.

Solution control (Fig. 5/3)

The squeegee water supply is regulated by a hand valve. The solution flow can be regulated between 0 gal/min and 0.9 gal/min.

Squeegee Lever (Fig. 5/4)

Use the hand lever to lift and lower the squeegee. This will deactivate or activate the vacuum motor.

Solution tank filter (Fig. 5/5)

While solution flows from tank to brush deck, it is cleaned by the filter element.

Recovery tank drain hose (Fig. 5/6)

This hose allows draining of the collected soiled water from the tank.

Solution tank drain hose (Fig.5/7)

This hose allows draining of the solution tank.

Brush ejector (Fig. 5/8)

The brush ejector makes brush removal fast and easy.

Power cord for charger (Fig. 5/9)

The power cord supplies the charger unit with power.

4 Technical Data

	Measure	Disc Brush 30"	Disc Brush 33"	Cylindr. Brush 28"
Machine length	in	65	68	64
Machine height	in	45	45	45
Machine width without Squeegee	in	31,5	35	31
Machine width with Squeegee	in	43	43	43
Working width	in	30	33	28
Squeegee width	in	43	43	43
Surface performance theoretical	ft ² /h	32300	36600	30150
Service voltage	V	24	24	24
Nominal power drive motor	W	480	480	480
Nominal power suction motor	W	520	520	520
Nominal power brush motor	W	2x720	2x912	2x876
Number of brushes	Qty.	2	2	2
Diameter of brushes	in	15	17	6
Work ride	mph	3,0	3,0	3,0
Solution tank	gallon	29,5	29,5	29,5
Recovery tank	gallon	28,5	28,5	28,5
Maximum inclination	%	10	10	10
Weight with solution and batteries	lbs	1150	1205	1111

***Add 7.3 kgs / 16 lbs for Gel Batteries**

Noise emission The sound pressure level measured under maximum conditions of use (LwA) according to DIN EN 60335-2-72 amounts to: The sound pressure level measured (at the ear of the driver) under normal conditions of use (LpA) according to DIN EN 60335-2-72 amounts to: Measurement inaccuracy (KpA):	 dB(A) 82 dB(A) 67 dB(A) 1.6
Vibration The frequency weighted acceleration measured according to DIN EN ISO 5349 which have an effect upon the upper limbs (hand-arm-system) amounts under normal working conditions:	 m/s ² < 0.8

5 Maintenance and Care

5.1 General



Before performing maintenance you are advised to read and comply with the Safety Information chapter!

Compliance with the recommended maintenance work schedule will give you the certitude of always having a reliable machine.

Daily or weekly maintenance and repair may be executed by the driver/operator having been trained accordingly. PowerBoss system maintenance work must be executed by qualified personnel only. Please contact your local PowerBoss Service Center or PowerBoss contract dealer. PowerBoss cannot be held liable for damages resulting from non-compliance with these instructions.

Please indicate the machine's serial number with any inquiry or spare parts order, see paragraph 1.7 - Labels at the

MachineNameplate.

5.1 PowerBoss System Maintenance

The PowerBoss System Maintenance:

- Guarantees reliable operability of the PowerBoss machines (Preventive maintenance)
- Minimizes operating costs, repair costs and maintenance costs
- Ensures long service life and operability of the machine

The PowerBoss System of Maintenance is structured in separate modules and determines specific technical works to be executed as well as the intervals for such maintenance. For any specific maintenance type, the replacement parts are determined and listed in spare part kits.

PowerBoss System Maintenance K:

To be performed by the customer in accordance to the maintenance and care instructions contained in the operating instruction manual (daily or weekly). The driver/operator will be instructed upon

delivery of the machine.

PowerBoss System Maintenance I :

(every 125 hours of operation)

To be performed by qualified personnel of an authorized PowerBoss Service Center in accordance with the machine-specific system maintenance including spare parts kit.

PowerBoss System Maintenance II:

(every 250 hours of operation)

To be performed by qualified personnel of an authorized PowerBoss Service Center in accordance with the machine-specific system maintenance including spare parts kit.

PowerBoss System Maintenance S:

(every 500 hours of operation safety check)

To be performed by a qualified personnel of authorized PowerBoss Service Center in accordance with the machine-specific system maintenance including spare parts kit.

5.2 Maintenance Document

<p style="text-align: center;">Handing over</p> <p>Upgrade Test drive Handing over to the customer Insttuction carried out on: at _____ operating hours</p>	<p style="text-align: center;">System Maintenance I 125 operating hours Workshop stamp</p> <p>carried out on: at _____ operating hours</p>	<p style="text-align: center;">System Maintenance II 250 operating hours Workshop stamp</p> <p>carried out on: at _____ operating hours</p>	<p style="text-align: center;">System Maintenance I 375 operating hours Workshop stamp</p> <p>carried out on: at _____ operating hours</p>
<p style="text-align: center;">System Maintenance S 500 operating hours Workshop stamp</p> <p>carried out on: at _____ operating hours</p>	<p style="text-align: center;">System Maintenance I 625 operating hours Workshop stamp</p> <p>carried out on: at _____ operating hours</p>	<p style="text-align: center;">System Maintenance II 750 operating hours Workshop stamp</p> <p>carried out on: at _____ operating hours</p>	<p style="text-align: center;">System Maintenance I 875 operating hours Workshop stamp</p> <p>carried out on: at _____ operating hours</p>
<p style="text-align: center;">System Maintenance S 1000 operating hours Workshop stamp</p> <p>carried out on: at _____ operating hours</p>	<p style="text-align: center;">System Maintenance I 1125 operating hours Workshop stamp</p> <p>carried out on: at _____ operating hours</p>	<p style="text-align: center;">System Maintenance II 1250 operating hours Workshop stamp</p> <p>carried out on: at _____ operating hours</p>	<p style="text-align: center;">System Maintenance I 1375 operating hours Workshop stamp</p> <p>carried out on: at _____ operating hours</p>

5.3 Maintenance Schedule

System Maintenance K (performed by the Customer)

The daily and weekly maintenance intervals are to be performed by the customer / operator.

To Be Performed	Interval	
	Daily	Weekly
Fill solution tank and proceed to chemical agent dosage	o	
Charge batteries	o	
Check scrub head and clean if required	o	
Check squeegee and clean if required	o	
Clean seal on lid of the recovery tank	o	
Empty recovery tank. Clean recovery tank and suction filter	o	
Check brushes/pads and replace if required		o
Clean suction hose from recovery tank		o
Check squeegee blades and turn around or replace if required		o
Clean drain hose of solution tank		o
Check solution supply to brushes and clean if required		o
Check solution filter and clean if required		o
Test drive and function test		o

System Maintenance I

The following maintenance works are to be performed by an authorized PowerBoss Service workshop.

To be performed	Interval
	Every 125 hours of operation
Check battery charger	o
Check tank lid seal of the recovery tank and replace if required	o
Check drain hose of the recovery tank and replace if required	o
Grease joints at the brush lift mechanism	o
Check wheel fixing screw and tighten (24 lb ft) if required	o
Check condition of tires	o
Grease joints at the squeegee holder	o
Test drive and function test	o

System Maintenance II

The following maintenance works are to be performed by an authorized PowerBoss Service workshop.

To Be Performed	Interval
	Every 250 hours of operation
Perform maintenance according to System Maintenance I	o
Inspect steering rollers for tread damage and bearing slackness and replace if required	o
Check drain hose from the recovery tank and replace if required	o
Check roller bumper of the brush deck and replace if required	o
Check suction hose for a tight fit and damages and replace if required	o
Check squeegee caster wheels and replace if required	o
Test drive and function test	o

System Maintenance S (Safety check)

The following maintenance works are to be performed by an authorized PowerBoss Service workshop at least once yearly.

To be Performed	Interval
	Every 500 hours of operation
Perform maintenance work according to System Maintenance II	o
Clean drive motor from carbon dust and check carbon brushes for smooth operation and wear and replace carbon brushes if required	o
Clean brush motors from carbon dust and check carbon brushes for smooth operation and wear and replace carbon brushes if required	o
Test drive and function test	o

5.4 Battery Systems

- 1 LDS Display
- 2 Charger Indicator
- 3 Charger
- 4 AC Power Cord for Charger
- 5 Battery Connector
- 6 Batteries
- 7 Recovery Tank
- 8 Support
- 9 Wiring Diagram



The handling and changing of batteries by qualified persons only!

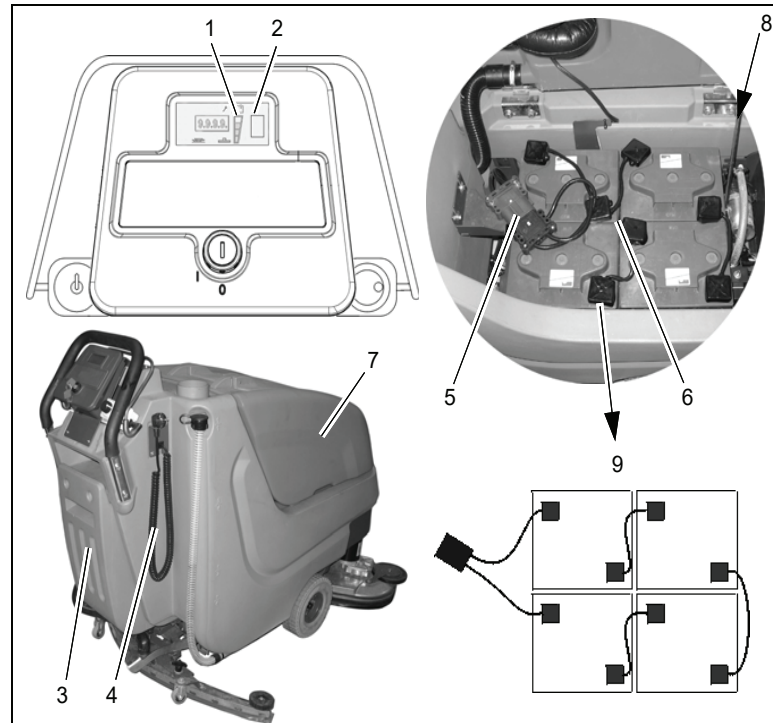

Fig.7

5.4.1 Charging The Batteries

Use the integrated battery charger (Fig.7/3) to charge batteries. Proceed to connect the charger to an AC outlet by the integrated cord (Fig. 7/4) with safety plug. Charging batteries is recommended if at least one bar of the LDS display has extinguished after operation of the machine. You are required to observe the operating instructions of the charger as well as the operating instructions of the battery manufacturer.



Charge the batteries properly before starting the machine for the first time. PowerBoss cannot be held liable for battery damage resulting from failure to initially charge batteries.



Provide sufficient ventilation of areas where batteries are being charged.
Explosion hazard

5.4.2 Low Discharge Signal Sender (LDS)

The machine has been equipped with a charge indicator to prevent the batteries from low discharge. This low discharge signal sender has been integrated into the electronics. If other batteries are used, readjustment of the low discharge signal sender is required.



Only PowerBoss contract workshops are authorized to make adjustments to the low discharge signal sender.

5.4.3 Removing Batteries

1. Park machine on level ground.
2. Switch off machine by key switch.
3. Open empty dirty water tank (Fig.7/7) and secure with support (Fig. 7/8).
4. Disconnect battery plug (Fig. 7/5).
5. Disconnect battery connection cables.
6. Remove batteries

5.4.4 Installing Batteries



Do not make changes to the center of gravity. Only use batteries as recommended at the prescribed position.

1. Turn off machine by the ignition switch.
2. Open empty dirty water tank (Fig.7/7) and secure by support (Fig. 7/8).
3. Place batteries into holder according to figure.
4. Connect battery poles and enclosed connecting cables according to wiring diagram (Fig.7/9). Provide for tight fitting and grease poles.

5.4.5 Disposal of Batteries

Used batteries labeled with the recycling sign contain reusable substances, such batteries must not be added to normal household waste.

5.5 Solution Tank

- 1 Solution Tank
- 2 Solution Full Marker
- 3 Fill Level Hose
- 4 Clean Water Filter
- 5 Solution Tank Lid

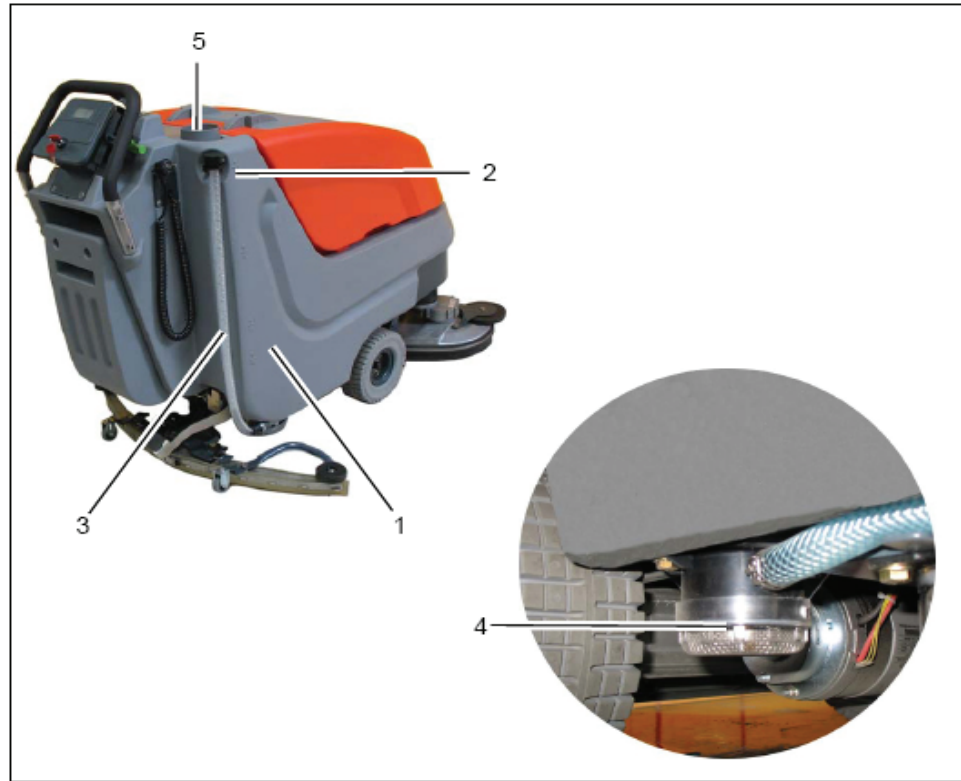

Fig.8

5.5.1 Filling the Solution Tank

Fill solution tank (Fig. 8/1) before operation or as required. Park vehicle on level ground. Open tank lid (Fig. 8/5) and fill tank up to the maximum (1/1 marker) (Fig. 8/2). Alternatively, filling of the machine via quick coupling (Fig. 8/6) is available. Before doing so, connect the filling hose of the metering unit to the quick coupler. The floater valve automatically closes after the maximum filling level has been attained. (Refer to specific operating instructions for information on operation of the metering unit) The maximum service pressure of the floater unit is 87 psi. (6 bar)

5.5.2 Empty the Solution Tank

Park vehicle such that the fill level hose (Fig. 8/3) is located above the drain aperture in the floor. Take fill level hose from holder and remove cap.

5.5.3 Cleaning Clear Water Filter

Check clean water filter (Fig. 8/4) at weekly intervals. Clean or replace if required.

NOTICE Only clean solution filter when the solution tank is empty.

1. Empty solution solution tank (Fig. 8/1) see paragraph 5.5.2.
2. Unscrew filter cap.
3. Remove the filter element from the filter case for cleaning. Replace if required.
4. Reinstall filter element and filter cap.

5.6 Recovery Tank

- 1 Recovery Tank
- 2 Recovery Tank Drain Hose
- 3 Suction Filter
- 4 Recovery Tank Lid



Fig.9

5.6.1 Empty Recovery Tank

Clean recovery tank (Fig. 9/1) at daily intervals, as required or upon acoustic signal (increased suction motor speed).

1. Take machine to appropriate place for discharge.
2. Park machine such that drain hose reaches a drain aperture in the floor.
3. Switch off machine.



Observe the legal provisions and the local regulations for disposal of detergents!

4. Take drain hose (Fig. 9/2) from holder and empty dirty water tank completely.

5.6.2 Cleaning the Recovery Tank

Clean the recovery tank (Fig. 9/1) at daily intervals or as required.

1. Empty recovery tank, see paragraph 5.6.1.
2. Open the recovery tank lid (Fig. 9/4)
3. Take drain hose from holder (Fig. 9/2) and empty recovery tank completely.
4. Remove remaining dirt by rinsing with clean water.
5. Rinse drain hose as well.

5.6.3 Clean Suction Filter

Check suction filter (Fig. 9/3) for function at daily intervals and clean if required. The suction filter is clipped on and can be easily removed.

5.7 Scrub Head

- 1 Pedal for Scrub Head Lift
- 2 Scrub Head
- 3 Brush Ejectors
- 4 Deflector Roller
- 5 Squeegee Blade



Fig.10

5.7.1 Cleaning Brushes

Clean scrub brushes (Fig.10/2) at daily intervals or as required.

1. Use pedal (Fig. 10/1) to lift brush head.
2. Press brush ejectors (Fig. 10/3) down to remove brushes for cleaning.

5.7.2 Changing Brushes

Check brushes for wear at weekly intervals. Replace brushes if bristles are worn down to a length of 1.5 cm.

1. Use pedal (Fig. 10/1) to lift scrub head.
2. Press brush ejectors (Fig. 10/3) down to remove old brushes.
3. Push new brush under brush head and use both hands to press install. Brushes should seat into position.

5.7.3 Changing Deflector Roller

Check deflector roller (Fig. 10/4) at weekly intervals and replace as required.

5.7.4 Changing Scrub Head Skirt

Check skirt (Fig. 10/5) at weekly intervals. Change as required. Open toggle-type fastener and remove skirt. mounting skirt is in reverse order.

5.8 Cylindrical Brush Deck

1. Brush toothing
2. Dirt hopper
3. Cylindrical brush deck
4. Deflector Rollers
5. Quick-release
6. Feed inlet
7. Brush seating
8. Locking lever

5.8.1 Clean Dirt Hopper

Clean dirt hopper (Fig. 11/2) at daily intervals or as required.

Remove dirt hopper from the right machine side (seen in direction of travel). Use quick-release (Fig. 11/5) to loosen feed inlet (Fig. 11/6) and clean dirt hopper.

5.8.2 Remove Brushes

1. Release brush seating (Fig. 11/7) by locking lever (Fig. 11/8).
2. Remove brush seating by lowering and removing it to the front.
3. Remove and check the brushes.

5.8.3 Clean Brushes

Clean brushes in the brush deck at daily intervals or as required.

5.8.4 Fit Brushes

Check brushes in the brush deck for wearing at weekly intervals and replace as required.

1. Insert brush into brush deck and let it catch (brush toothing (Fig. 11/1) as to point to the outside).
2. Place brush seating and lock by lever.

5.8.5 Change Deflector Roller

Check deflector rollers (Fig. 11/4) at weekly intervals and replace if required.

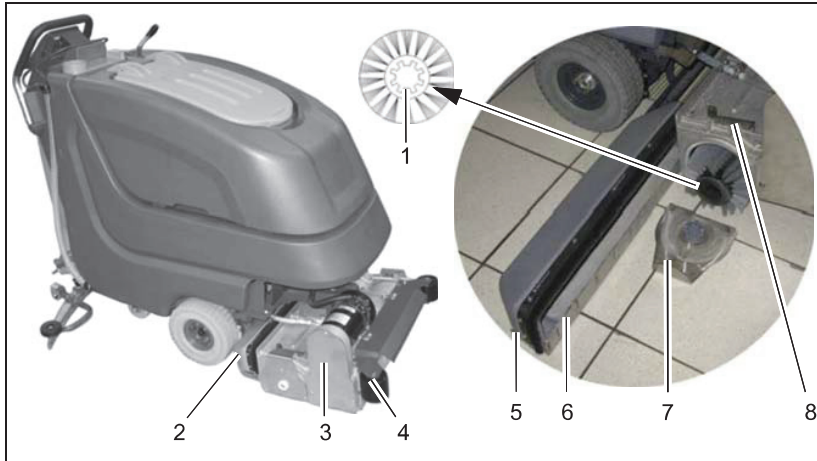

Fig.11

5.9 Squeegee

- 1 Squeegee
- 2 Star-shaped knob
- 3 Adjusting screw for angle adjustment
- 4 Suction hose
- 5 Fastening device
- 6 Washers for height adjustment

5.9.1 Cleaning the Squeegee

Check the squeegee (Fig. 11/1) daily and clean as necessary.

To clean it lift the squeegee out, pull off the suction hose (Fig. 11/4), loosen the two star-shaped knobs (Fig. 11/2) and remove the squeegee.

5.9.2 Changing the Squeegee Blades

Check the inner and outer squeegee blades on the squeegee (Fig. 11/1) weekly for signs of wear. The squeegee blades can be re-used by turning them.

1. Lift the squeegee out.
2. Pull off the suction hose, loosen the two star-shaped knobs and remove the squeegee.
3. Unlock the fastening device (Fig. 11/5) and remove the outer squeegee blade. Turn the squeegee blade or install a new one, as necessary. Change the inner squeegee blade in the same way.

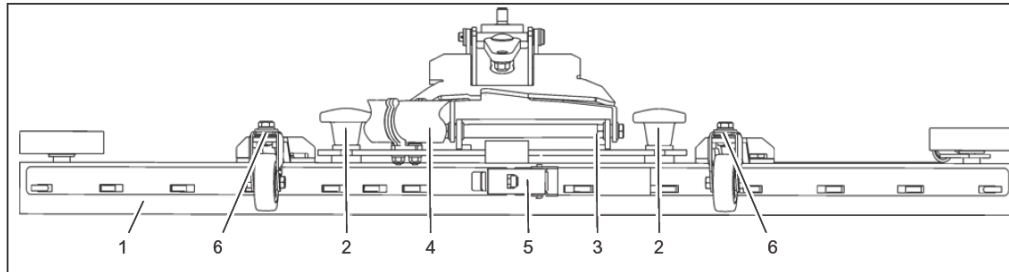

Fig. 11

5.9.3 Adjusting the Blades Angle Adjustment

The angle adjustment is the decisive factor in ensuring that the squeegee blades on the squeegee lie evenly on the floor.

1. Park the machine on a level surface and lower the squeegee.
2. Loosen the counternut on the adjusting screw (Fig. 12/1) and adjust the squeegee using the adjusting screw so that the ends of the squeegee blades have contact with the floor.

Figure A:

Turn the adjusting screw counter-clockwise: The clearance between squeegee blade and floor is reduced in the center.

Figure B:

Turn the screw clockwise: The clearance between squeegee blade and floor is increased in the center.

3. Switch the machine on and check the suction pattern. When the machine is in operation, the entire surface of the sealing strips (center and outer areas) must be applied as evenly as possible.
4. Tighten the counternut on the adjusting screw at 5 lb ft.

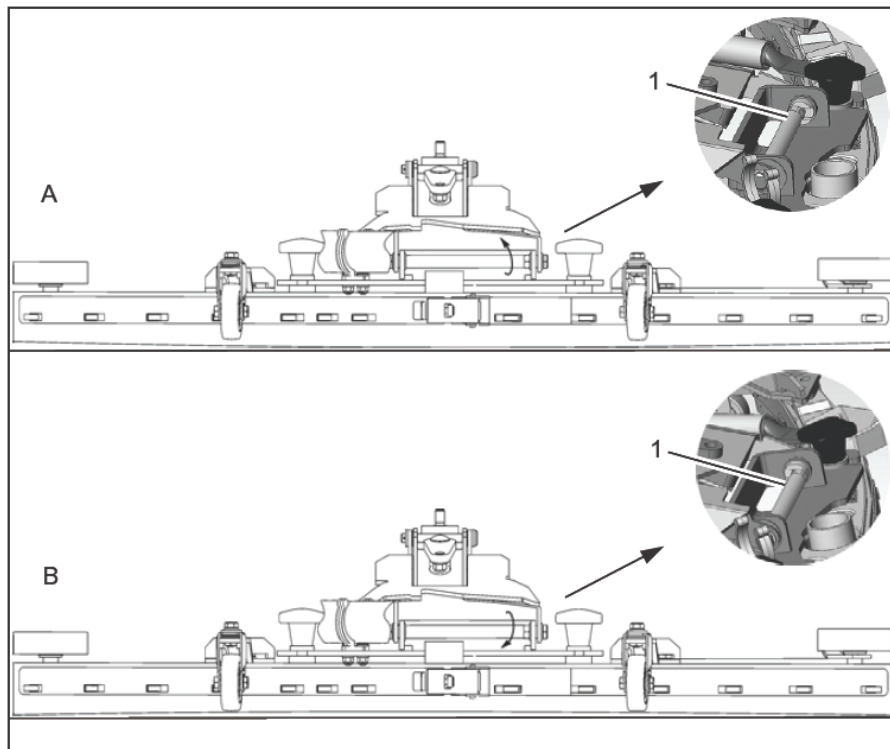

Fig. 12

Height Adjustment

The height adjustment is set to 3mm at the factory. If streaks are produced, despite an optimum angle adjustment, the clearance between the casters and floor must be adjusted by changing the number of washers on the holder.

In case of very smooth floors, e.g. finished floors, PVC, linoleum, etc. Number of washers = 2. This corresponds to a clearance of approximately 2mm.

In cases of very uneven floors, e.g. poorly laid tiles (water does not run off) Number of washers = 4. This corresponds to a clearance of approximately 4mm.



The squeegee is equipped with two additional casters which are adjusted at the factory to a distance of 10mm to the floor by means of spacers.

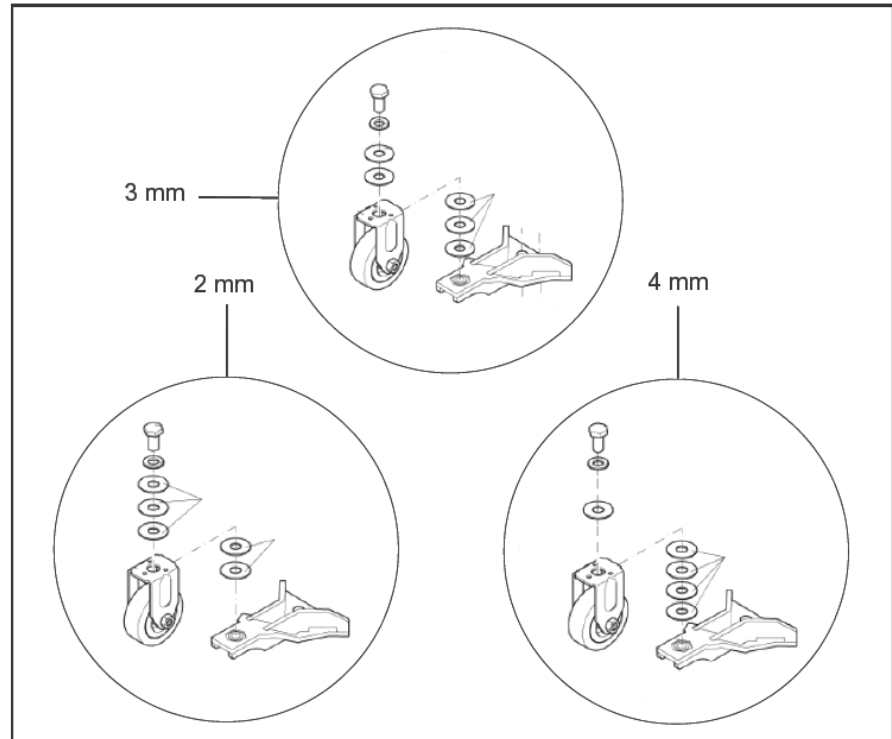

Fig. 13

PowerBoss[®]
The Power of Clean

“The Power of Clean”

**PowerBoss is a Full Line Manufacturer of Sweepers and Scrubbers,
for Industrial Facilities.**

PowerBoss, Inc.
A member Of The Hako Group

988745UMPB REV A 09/25